

BRITISH STANDARD

2000-11-17

**BS 4592-1:
1995**

*Incorporating
Amendment No. 1*

Industrial type metal flooring, walkways and stair treads —

**Part 1: Specification for open bar
gratings**



ICS 91.060.30

NO COPYING WITHOUT BSI PERMISSION EXCEPT AS PERMITTED BY COPYRIGHT LAW

BSI

Contents

	Page
Committees responsible	Inside front cover
Foreword	ii
1 Scope	1
2 References	1
3 Definitions	1
4 Information to be supplied	2
5 Materials	3
6 Sizes	3
7 Permissible tolerances	3
8 Construction	4
9 Performance	4
10 Marking	5
Annex A (normative) Method of test for strength and deflection	6
Annex B (informative) Recommendations for installation of gratings	6
Figure 1 — Grating terms	2
Figure 2 — Imposed load on treads	5
Figure B.1 — Fixing dimensions for bolted end plates	8
Table 1 — Permissible tolerances	3
Table 2 — Manufacturing tolerances	4
Table 3 — Loads	4
Table 4 — Load factors and combinations	5
List of references	Inside back cover

Foreword

This part of BS 4592 has been prepared by Technical Committee B/208. It supersedes BS 4592-1:1987 which is withdrawn.

This revision upgrades the sizes of bars, increases the range of maximum permissible deviations and specifies maximum permissible manufacturing tolerances.

BS 4592 is published in five parts as follows:

- *Part 1: Specification for open bar gratings;*
- *Part 2: Specification for expanded metal grating panels;*
- *Part 3: Specification for cold formed planks;*
- *Part 4: Specification for glass reinforced plastics open bar gratings;*
- *Part 5¹⁾: Specification for solid plates in steel, aluminium and glass reinforced plastics (GRP).*

A British Standard does not purport to include all the necessary provisions of a contract. Users of British Standards are responsible for their correct application.

Compliance with a British Standard does not of itself confer immunity from legal obligations.

Summary of pages

This document comprises a front cover, an inside front cover, pages i and ii, pages 1 to 8, an inside back cover and a back cover.

The BSI copyright notice displayed in this document indicates when the document was last issued.

Sidelining in this document indicates the most recent changes by amendment.

¹⁾ In preparation.

1 Scope

This part of BS 4592 specifies requirements for aluminium and steel (including stainless steel) open bar gratings intended for use in flooring, walkways and stair treads.

NOTE 1 Annex A specifies a method of test for strength and deflection.

NOTE 2 Annex B gives recommendations for installation of gratings.

NOTE 3 This standard does not cover agricultural uses (see BS 5502).

2 References

2.1 Normative references

This British Standard incorporates, by reference, provisions from specific editions of other publications. These normative references are cited at the appropriate points in the text and the publications are listed on the inside back cover. Subsequent amendments to, or revisions of, any of these publications apply to this British Standard only when incorporated in it by updating or revision.

2.2 Informative references

This British Standard refers to other publications that provide information or guidance. Editions of these publications current at the time of issue of this standard are listed on the inside back cover, but reference should be made to the latest editions.

3 Definitions

For the purposes of this part of BS 4592 the definitions given in BS 5395-1 and BS 5395-3 and BS 6100-1 apply, together with the following.

NOTE Definitions of some common terms are illustrated in Figure 1.

3.1 types of bar

3.1.1

loadbearing

longitudinal loadbearing member spanning between supports

3.1.2

transverse

member fixed at right angles to loadbearing bars to provide lateral restraint

3.1.3

pressed

member fixed diagonally between adjacent loadbearing bars to provide lateral restraint

3.1.4

binding

bar or section fixed to the edge of a grating, flush with the top of the loadbearing bar

3.1.5

serrated

bar with serrated top surface

3.2

nosing

member attached to the front edge of a stair tread or to a grating at the head of a stair

3.3

end plate

plate fixed to stair tread for attachment to a string

3.4

support

member supporting grating

3.5

curb angle

support fixed to concrete or steelwork around perimeter of grating

3.6

cut-out

area where grating has been removed to permit services, plant or structural members to pass through or to clear obstructions

3.7

straight shaping

part of cut-out with straight edges

3.8

curved shaping

part of cut-out with curved edges

3.9

toe plate

flat bar around a cut-out projecting above the top of the loadbearing bars

3.10 sizes of gratings

3.10.1

length (span)

overall size of grating measured in a direction parallel to the loadbearing bars

3.10.2

width

overall size of grating measured in a direction at right angles to the loadbearing bars

3.10.3

pitch

distance centre-to-centre of loadbearing bars or between centres of points of lateral restraint to loadbearing bars or between serrations

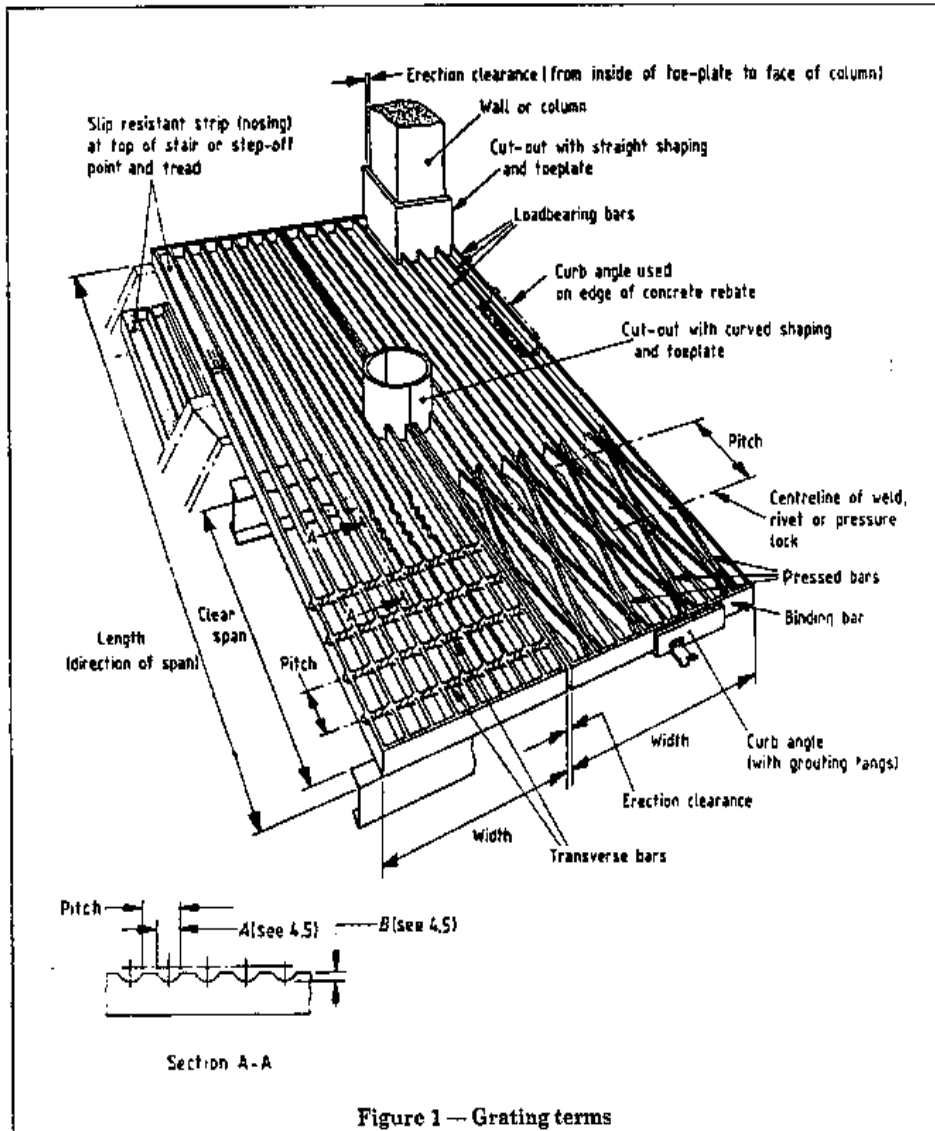

Figure 1 — Grating terms

3.10.4

depth

overall depth of loadbearing bar

3.11

effective span

clear span between supports

4 Information to be supplied

The following information to be supplied by the purchaser shall be fully documented. Both the definitive requirements specified throughout the standard and the following documented items shall be satisfied before a claim of compliance with the standard can be made and verified:

- a) where appropriate, scale plans of the area to be covered, indicating:
 - 1) position of all supporting members;

- 2) direction of the loadbearing bars in relation to the flooring layout or walkway;
- 3) location and size of any cut-outs necessary for columns, cable and pipe openings, etc. (Where pipe movement occurs, the purchaser will need to state the limits of the extreme conditions);
- 4) location and size of any toe plates to be fixed to the flooring or walkways.
- b) type of grating (see Figure 1) and the depth required if known;
- c) type of top surface (plain or serrated);
- d) materials from which the flooring, walkway or stair treads are to be fabricated;
- e) loading for which the flooring, walkway or stair treads are to be designed (see Table 3). For wheel loading, the tread area, maximum wheel load and direction of travel will need to be stated. For other concentrated loads (see Table 3) the concentrated load area will need to be stated.
- f) any limitations on depth of flooring or walkway;
- g) any limitations on size or weight of flooring or walkway;
- h) any limitation on the use of gratings where the loadbearing bars span a number of supporting members;
- i) whether the flooring or walkway is to be removable;
- j) method of fixing (clips or welding, see annex B);
- k) whether the flooring or walkway is internal or external to a building and whether any particular corrosive conditions exist;
- l) type of finish;
- m) conditions affecting the sequence or time schedule of erection of floors or walkways, including heights relative to ground level.

5 Materials

5.1 Steel

Low carbon steel shall as a minimum conform to BS EN 10025.

Stainless steel shall as a minimum conform to BS 1449-2 for austenitic steel.

5.2 Aluminium

Aluminium shall as a minimum conform to BS 1474.

5.3 Protection against corrosion

Gratings shall be free draining. Any hot dip galvanizing shall be as specified in BS 729.

NOTE The requirements for protection against corrosion will vary according to the end use and should be agreed between manufacturer and purchaser. For external protection, hot dip galvanizing is recommended.

6 Sizes

6.1 The minimum thickness of loadbearing bars shall be 3 mm, subject to the tolerances given in the appropriate material standard. The thickness of binding bars (see 3.1.4) that are loadbearing shall be not less than the thickness of the loadbearing bars (see 3.1.1).

6.2 The cross-sectional area of transverse bars (see 3.1.2) shall be not less than 20 mm² for flat bars, 25 mm² for square and round bars and for pressed bars (see 3.1.3) not less than 45 mm².

6.3 The clear distance between loadbearing bars or adjacent panels of grating, providing they are securely fixed into position shall not exceed 40 mm.

6.4 The pitch of transverse bars shall not exceed 165 mm and the pitch of pressed bars shall not exceed 210 mm.

6.5 For serrations (see Figure 1) dimension A shall be not less than 55 % of their pitch and dimension B shall be not less than 1.5 mm. There shall be not less than five serrations per 100 mm length of grating.

7 Permissible tolerances

7.1 The maximum permissible deviations from work sizes of gratings shall be as shown in Table 1.

Table 1 — Permissible tolerances

Location	Tolerance in mm
Length of grating	+0 -6
Width of grating	+0 -5
Depth of loadbearing bar:	
up to and including 25 mm	+1.0 -0.5
over 25 mm up to 50 mm	+1.5 -0.75
over 50 mm up to 100 mm	+2.0 -1.0
over 100 mm up to 150 mm	+2.0 -1.5
Thickness of loadbearing bar:	
up to 10 mm	± 0.4
over 10 mm up to 15 mm	± 0.5

7.2 The maximum permissible manufacturing tolerances shall be as given in Table 2.

Table 2 — Manufacturing tolerances

Location	Tolerance
Difference between diagonals	5 mm (out of squareness of grating panel)
Cross bars in either direction from perpendicular alignment with bearing bars	1 : 100
Cross bar spacing	± 5 mm per 1 500 mm length of loadbearing bars
Loadbearing bar lean	1 : 10
Transverse bow of panel before fastening to supports	1 : 100
Longitudinal bow of panel before fastening to supports	1 : 200

8 Construction

8.1 Loadbearing bars shall be provided with lateral restraint by means of transverse bars (see 3.1.2) or pressed bars (see 3.1.3), fixed at each point of intersection or contact with the loadbearing bars by means of welding (see 8.2), riveting or pressure locking.

8.2 Welding of steel shall either be arc welding in accordance with BS 5135 or resistance welding.

NOTE In resistance welding heat is generated at the metal intersection points by an electric current. As the forging temperature is reached, pressure is applied and the materials are forge welded together.

Welding of aluminium shall be in accordance with BS 8118-2.

8.3 Where the function of binding bars excludes load transfer, they shall be at least secured to the nearest loadbearing bar at every 180 mm pitch. Where the binding bars are loadbearing, they shall be secured to every loadbearing bar. If welded, the fillet weld leg length shall at least be equivalent to the thickness of the loadbearing bar, throughout the depth of the binding bar and one side of the loadbearing bar.

8.4 Longitudinal ties between supports shall be below the underside of loadbearing bars.

8.5 When binding bars are applied along the length of a grating, they shall be secured at every transverse bar or at every point where they are in contact with a pressed bar.

8.6 Where a cut-out (see 3.6) is required in a grating, the opening shall be trimmed with a binding bar or, where specified, a toe plate.

8.7 Where binding bars are loadbearing they shall at least be equivalent in depth to the loadbearing bars, otherwise they may be reduced in depth to aid free draining (see 5.3).

8.8 Where nosings are specified, they shall be used consistently throughout the stair.

9 Performance

NOTE The values given in Table 3 and Table 4 are taken from BS 5395-3 and BS 5950-1 respectively.

Table 3 — Loads^a

Use of grating	UDL ^b kN/m ²	Concentrated load (at 1.0 m centres) over square of 300 mm side kN
<i>Light duty</i>		
Access limited to one person	3.0	1.0
<i>General duty</i>		
Regular two-way pedestrian traffic	5.0	1.0
<i>Heavy duty</i>		
High density pedestrian traffic	7.5	1.0 ^c

NOTE 1 Gratings required to take vehicle loads travelling at 90° to the direction of loadbearing bars, i.e. across the loadbearing bars, shall either have pressed bars, or transverse bars that pass through the loadbearing bars below the top of the grating, in order to reduce the tendency for loadbearing bars to flip over under accelerating or braking conditions across the grating widths.

NOTE 2 For vehicular traffic, unfactored wheel loads may have the permissible stress increased by 10 % providing there is a 25 % increase made to the unfactored load to allow for impact.

^a Loads are to be taken to be safe working loads for permissible stress design or characteristic loads for limit state design.

^b The uniformly distributed load (UDL) is the equivalent uniformly distributed static load per square metre of plan area.

^c Greater concentrated loads may be required where machinery or other items are to be placed on the flooring.

9.1 General

Open bar gratings shall withstand the appropriate unfactored loads given in Table 3. Where a cut-out is required, the remaining area of the grating shall be able to carry the same load.

The positions of concentrated loads shall either be those which produce the maximum stresses, or, where deflection is the design criterion, those which produce maximum deflection.

NOTE The safe working loads or characteristic loads for a range of effective spans should be stated in trade literature.

9.2 Flooring and walkways

When calculated in accordance with BS 5950-1 or when tested in accordance with annex A, the flooring or walkway shall be shown to conform to the following requirements.

- It shall have a load factor, for dead and imposed loads not less than that given in Table 4 when subjected to the appropriate unfactored load (see 9.1).
- It shall deflect elastically, not more than 1/200 times the effective span (see 3.10) or 10 mm, whichever is lesser, when subjected to the appropriate unfactored load.
- It shall have a load factor not less than 1.6 (see Table 4) when subjected to a single concentrated unfactored imposed load of 1.0 kN spread over an area of 300 mm × 300 mm, so placed as to produce maximum stress or deflection (see 9.1).

Table 4 — Load factors and combinations

Loading	Factor
Dead load	1.4
Dead load restraining uplift or overturning	1.0
Imposed load	1.6

NOTE For further information see 2.4 of BS 5950-1:1990.

9.3 Treads

When calculated in accordance with BS 5950-1 or when tested in accordance with annex A a tread with a concentrated unfactored imposed load of 1.5 kN spread over an area of 150 mm × 150 mm, placed at the centre of the front edge of the tread (see Figure 2), shall be shown to conform to the following requirements.

- It shall have a load factor not less than 1.6 (see Table 4).
- It shall deflect elastically not more than 1/200 times the effective span or 6 mm, whichever is the lesser.

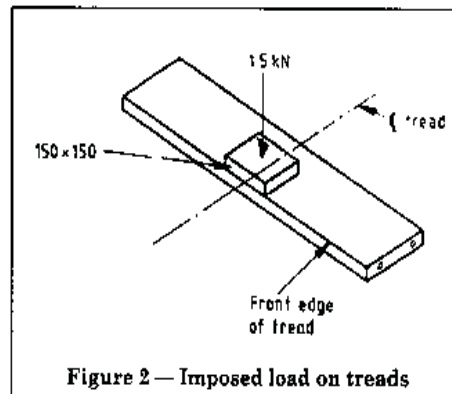

Figure 2 — Imposed load on treads

10 Marking

10.1 The following particulars shall be clearly marked on the delivery note, invoice or supplier's certificate supplied with the consignment of gratings:

- name, trademark or other means of identification of the manufacturer;
- the number and date of this British Standard, i.e. BS 4592-1:1995²⁾.

10.2 Gratings shall be marked with a reference number to assist assembly on site.

²⁾ Marking BS 4592-1:1995 on or in relation to a product represents a manufacturer's declaration of conformity, i.e. a claim by or on behalf of the manufacturer that the product meets the requirements of the standard. The accuracy of the claim is solely the claimant's responsibility. Such a declaration is not to be confused with third party certification of conformity, which may also be desirable.

Annex A (normative)

Method of test for strength and deflection

A.1 Test procedure

The test shall be carried out in accordance with A.2 to A.5, using the test procedures given in section 7 of BS 5950-1:1990.

A.2 Method of support

A sample of flooring or walkway not greater than 1 m wide, or a tread, shall be simply supported at each end, using the manufacturer's specified fixing pattern.

A.3 Uniformly distributed load (flooring or walkway)

A.3.1 Load application

The loading applied shall be uniformly distributed across the full width of the test sample over the effective span (see 3.11) and shall represent the appropriate unfactored uniformly distributed pedestrian load required to produce no more than the maximum recommended deflection.

Loading shall be such as to offer no restraint to torsion, lateral buckling or other determination at the section, e.g. by using rollers.

A.3.2 Deflection monitoring

Vertical deflection of the walking surface shall be monitored at mid-span and at each end support, the actual elastic deflection being the difference between the maximum deflection and average of the end deflections.

A.4 Concentrated load (flooring or walkway)

A.4.1 Load application

A single concentrated load shall be applied to the centre of the sample via a spreader plate of dimensions 300 mm × 300 mm.

A.4.2 Deflection monitoring

Vertical deflection of the walking surface shall be monitored at mid-span and at each end support, the actual elastic deflection being the difference between the maximum deflection and average of the end deflections.

A.5 Concentrated load (treads)

A.5.1 Load application

A single concentrated load shall be applied to the centre of the front edge of the tread via a spreader plate of dimensions 150 mm × 150 mm (see Figure 2).

A.5.2 Deflection monitoring

Vertical deflection of the front edge shall be monitored at mid-span and at each end support, the actual elastic deflection being the difference between the maximum deflection and average of the end deflections.

Annex B (informative)

Recommendations for installation of gratings

B.1 General

Gratings should be fixed or contained in such a manner that they will not move laterally or away from their supporting members. The minimum extension of grating over supports should be 25 mm.

Where it is possible for gratings to move in the direction of span away from their supporting structure, the design of either the gratings or the structure should include a suitable method of minimizing movement. For example, gratings may be designed to include either small pieces of flat bar or angle section fixed to them in such a manner as to restrict their movement by having them protrude below the bottom surface of the gratings at a distance of not more than 10 mm away from the edges of their supporting structure. Alternatively, the supporting structure may be designed to include small pieces of flat bar attached to its top surface in such a manner and position as to prevent the gratings moving significantly in any direction when not fixed down.

For flooring, grating widths should be chosen so that, as far as possible, no grating is less than 300 mm in width. Where a narrower width is unavoidable, the grating should be adequately connected to an adjacent grating.

B.2 Fixing clips

All gratings should be fixed securely to the supporting structure using not less than two clips for each grating where panels are connected together, or four clips for each grating where panels are not connected together. Fixing clips should be used for all continuous span gratings and for shaped gratings where any side or edge of a grating may be subject to uplift as a result of a non-uniform imposed load. Wherever practicable, the clips should be designed so that they may be fixed or removed by persons working from the surface of the grating secured by those clips. The projection of a clip above the grating surface should be not greater than the thickness of the clip or 4 mm, whichever is the lesser. The minimum thickness of the clip should normally be 3 mm; however, this may be reduced if precautions against corrosion are taken. The minimum diameter of any fixing bolt should be 8 mm.

Fixing bolts should be supplied with either a lock nut or a tab washer to retain the nut, or have the fixing clip designed to retain the nut.

In areas where grating deflections are at their extremes or where grating is known to be subject to high levels of vibration, a more positive method of fixing should be used, such as direct fixing of grating to supports by either welding to or bolting through their supports. Other methods of positive fixings recommended in lieu of friction grip fixing clips are drilling and tapping of supporting steelwork, welding studs or bosses to the supports, or driving studs into the supports using an appropriate tool.

B.3 Toe plates

Toe plates should not be fixed to gratings except around cut-outs. Fixing should be in accordance with the appropriate method specified for binding bars in clause 8. The thickness of a toe plate should be not less than 5 mm or the thickness of the loadbearing bars, whichever is the greater.

When toe plates form part of the grating, the height of the upstand should be not less than 100 mm and not greater than five times the depth of the loadbearing bars or 150 mm, whichever is the lesser.

Stanchions should not be fixed to toe plates, unless the toe plates are structural members or are stiffened at the fixing point by structural members.

B.4 End plates for stair treads

End plates for stair treads should be welded for their full length along one side to each loadbearing bar, unless the load is transferred through a ledge support secured to, or forming part of, the end plate.

The fixing sizes for bolted end plates should be as given in Figure B.1.

B.5 Erection clearances

The following minimum clearances should be allowed for erection, subject to any increases brought about by permissible tolerances (see clause 7):

between grating panel sides	3 mm
between grating panel ends	6 mm
between edge of grating and adjacent structures	10 mm

NOTE For maximum distance between adjacent grating sections in a continuous floor see 6.3.

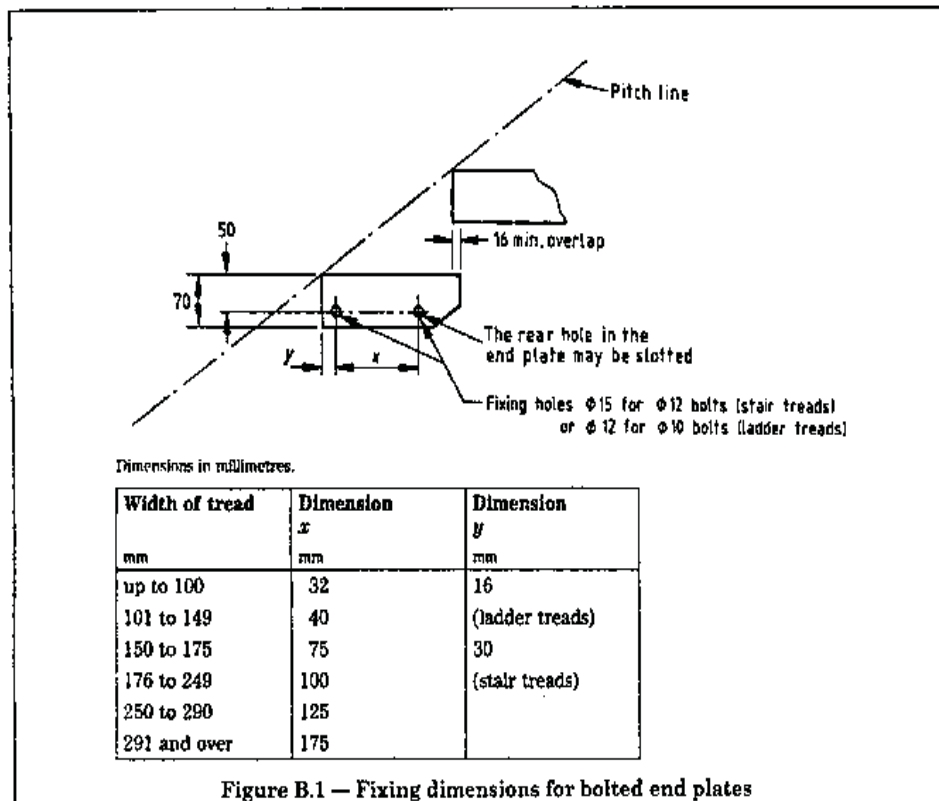

List of references (see clause 2)

Normative references

BSI publications

BRITISH STANDARDS INSTITUTION, London

- BS 729:1971, *Specification for hot dip galvanized coatings on iron and steel articles.*
- BS 1449, *Steel plate, sheet and strip.*
- BS 1449-2:1983, *Specification for stainless and heat resisting steel plate, sheet and strip.*
- BS 1474:1987, *Specification for wrought aluminium and aluminium alloys for general engineering purposes: bars, extruded round tubes and sections.*
- BS 5135:1984, *Specification for arc welding of carbon and carbon manganese steels.*
- BS 5395, *Stairs, ladders and walkways.*
- BS 5395-1:1984, *Code of practice for the design of straight stairs.*
- BS 5395-3:1985, *Code of practice for the design of industrial type stairs, permanent ladders and walkways.*
- BS 5950, *Structural use of steelwork in building.*
- BS 5950-1:1990, *Code of practice for design in simple and continuous construction: hot rolled sections.*
- BS 6100, *Glossary of building and civil engineering terms.*
- BS 6100-1, *General and miscellaneous.*
- BS 8118, *Structural use of aluminium.*
- BS 8118-2:1991, *Specification for materials, workmanship and protection.*
- BS EN 10025:1993, *Hot rolled products of non-alloy structural steels. Technical delivery conditions.*

Informative reference

BSI publication

BRITISH STANDARDS INSTITUTION, London

- BS 5502, *Buildings and structures for agriculture.*

BSI — British Standards Institution

BSI is the independent national body responsible for preparing British Standards. It presents the UK view on standards in Europe and at the international level. It is incorporated by Royal Charter.

Revisions

British Standards are updated by amendment or revision. Users of British Standards should make sure that they possess the latest amendments or editions.

It is the constant aim of BSI to improve the quality of our products and services. We would be grateful if anyone finding an inaccuracy or ambiguity while using this British Standard would inform the Secretary of the technical committee responsible, the identity of which can be found on the inside front cover. Tel: 020 8996 9000. Fax: 020 8996 7400.

BSI offers members an individual updating service called PLUS which ensures that subscribers automatically receive the latest editions of standards.

Buying standards

Orders for all BSI, international and foreign standards publications should be addressed to Customer Services. Tel: 020 8996 9001. Fax: 020 8996 7001.

In response to orders for international standards, it is BSI policy to supply the BSI implementation of those that have been published as British Standards, unless otherwise requested.

Information on standards

BSI provides a wide range of information on national, European and international standards through its Library and its Technical Help to Exporters Service. Various BSI electronic information services are also available which give details on all its products and services. Contact the Information Centre. Tel: 020 8996 7111. Fax: 020 8996 7048.

Subscribing members of BSI are kept up to date with standards developments and receive substantial discounts on the purchase price of standards. For details of these and other benefits contact Membership Administration. Tel: 020 8996 7002. Fax: 020 8996 7001.

Copyright

Copyright subsists in all BSI publications. BSI also holds the copyright, in the UK, of the publications of the international standardization bodies. Except as permitted under the Copyright, Designs and Patents Act 1988 no extract may be reproduced, stored in a retrieval system or transmitted in any form or by any means – electronic, photocopying, recording or otherwise – without prior written permission from BSI.

This does not preclude the free use, in the course of implementing the standard, of necessary details such as symbols, and size, type or grade designations. If these details are to be used for any other purpose than implementation then the prior written permission of BSI must be obtained.

If permission is granted, the terms may include royalty payments or a licensing agreement. Details and advice can be obtained from the Copyright Manager. Tel: 020 8996 7070.